

SECTION **FSU**
FRONT SUSPENSION

A
B
C
D

FSU

CONTENTS

2WD	AWD	
SERVICE INFORMATION	SERVICE INFORMATION	2 19
PRECAUTIONS	PRECAUTIONS	2 19
Caution	Caution	2 19
PREPARATION	PREPARATION	3 20
Special Service Tool	Special Service Tool	3 20
Commercial Service Tool	Commercial Service Tool	3 20
NOISE, VIBRATION AND HARSHNESS (NVH) TROUBLESHOOTING	NOISE, VIBRATION AND HARSHNESS (NVH) TROUBLESHOOTING	4 21
NVH Troubleshooting Chart	NVH Troubleshooting Chart	4 21
FRONT SUSPENSION ASSEMBLY	FRONT SUSPENSION ASSEMBLY	5 22
On-Vehicle Inspection	On-Vehicle Inspection	5 22
Wheel Alignment Inspection	Wheel Alignment Inspection	5 22
Component	Component	7 24
Removal and Installation	Removal and Installation	8 25
COIL SPRING AND SHOCK ABSORBER	COIL SPRING AND SHOCK ABSORBER	10 27
Removal and Installation	Removal and Installation	10 27
Disassembly and Assembly	Disassembly and Assembly	10 27
Disposal	Disposal	12 29
TRANSVERSE LINK	TRANSVERSE LINK	13 30
Removal and Installation	Removal and Installation	13 30
UPPER LINK	UPPER LINK	15 32
Removal and Installation	Removal and Installation	15 32
STABILIZER BAR	STABILIZER BAR	16 33
Removal and Installation	Removal and Installation	16 33
SERVICE DATA AND SPECIFICATIONS (SDS)	SERVICE DATA AND SPECIFICATIONS (SDS)	17 34
Wheel Alignment (Unladen *)	Wheel Alignment (Unladen*)	17 34
Ball Joint	Ball Joint	17 34
Wheelarch Height (Unladen*)	Wheelarch Height (Unladen*)	17 34

F
G
H
I
J
K
L
M
N
O
P

SERVICE INFORMATION

PRECAUTIONS

Caution

INFOID:000000005347645

- When installing rubber bushings, the final tightening must be carried out under unladen conditions with tires on ground. Oil might shorten the life of rubber bushings. Be sure to wipe off any spilled oil.
- Unladen conditions mean that fuel, engine coolant and lubricant are full. Spare tire, jack, hand tools and mats are in designated positions.
- After servicing suspension parts, be sure to check wheel alignment.
- Self-lock nuts are not reusable. Always use new ones when installing. Since new self-lock nuts are pre-oiled, tighten as they are.

PREPARATION

< SERVICE INFORMATION >

[2WD]

PREPARATION

Special Service Tool

INFOID:000000005347646

The actual shapes of Kent-Moore tools may differ from those of special service tools illustrated here.

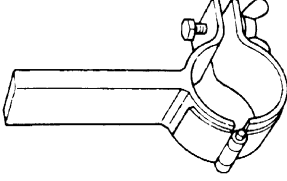
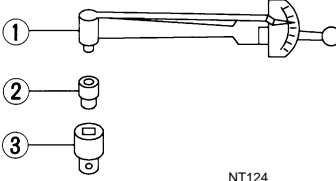
Tool number (Kent-Moore No.) Tool name	Description
ST35652000 (—) Shock absorber attachment	 ZZA0807D
ST3127S000 (See J-25765-A) Preload Gauge 1. GG91030000 (J-25765-A) Torque wrench 2. HT62940000 (—) Socket adapter 3. HT62900000 (—) Socket adapter	 NT124

A

B

C

D

FSU

F

G

H

I

Commercial Service Tool

INFOID:000000005347647

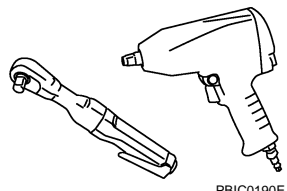
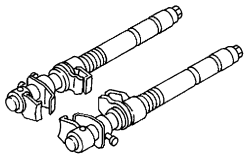
Tool name	Description
Power tool	 PBIC0190E
Spring compressor	 S-NT717

J

K

L

M

N

O

P

NOISE, VIBRATION AND HARSHNESS (NVH) TROUBLESHOOTING

< SERVICE INFORMATION >

[2WD]

NOISE, VIBRATION AND HARSHNESS (NVH) TROUBLESHOOTING

NVH Troubleshooting Chart

INFOID:000000005347648

Use chart below to find the cause of the symptom. If necessary, repair or replace these parts.

Reference page		FSU-7	FSU-10	—	—	—	FSU-7	FSU-5	FSU-16	NVH in PR section	NVH in FAX and FSU section	NVH in WT section	NVH in BR section	NVH in PS section	
Possible cause and SUSPECTED PARTS		Improper installation, looseness	Strut deformation, damage or deflection	Bushing or mounting deterioration	Parts interference	Spring fatigue	Suspension looseness	Incorrect wheel alignment	Stabilizer bar fatigue	PROPELLER SHAFT	FRONT AXLE AND FRONT SUSPENSION	ROAD WHEEL	BRAKES	STEERING	
Symptom	FRONT SUSPENSION	Noise	x	x	x	x	x	x	x	x	x	x	x	x	
		Shake	x	x	x	x	x	x	x	x	x	x	x	x	x
		Vibration	x	x	x	x	x	x	x	x	x	x	x	x	x
		Shimmy	x	x	x	x	x	x	x	x	x	x	x	x	x
		Judder	x	x	x	x	x	x	x	x	x	x	x	x	x
		Poor quality ride or handling	x	x	x	x	x	x	x	x	x	x	x	x	x

x: Applicable

FRONT SUSPENSION ASSEMBLY

< SERVICE INFORMATION >

[2WD]

FRONT SUSPENSION ASSEMBLY

On-Vehicle Inspection

INFOID:000000005347649

Make sure the mounting conditions (looseness, back lash) of each component and component conditions (wear, damage) are normal.

INSPECTION OF UPPER LINK BALL JOINT END PLAY

1. Set front wheels in a straight-ahead position. Do not depress brake pedal.
2. Place an iron bar or similar tool between transverse link and steering knuckle.
3. Measure axial end play by prying it up and down.

Axial end play : 0 mm (0 in)

CAUTION:

Be careful not to damage ball joint boot. Do not damage the installation position by applying excessive force.

SHOCK ABSORBER INSPECTION

Check for oil leakage, damage and breakage of installation positions.

Wheel Alignment Inspection

INFOID:000000005347650

DESCRIPTION

Measure wheel alignment under unladen conditions.

NOTE:

“Unladen conditions” means that fuel, engine coolant, and lubricant are full. Spare tire, jack, hand tools and mats are in designated positions.

PRELIMINARY CHECK

- Check tires for improper air pressure and wear.
- Check road wheels for runout. Refer to [WT-8](#).
- Check wheel bearing axial end play. Refer to [FAX-6, "On-Vehicle Inspection"](#).
- Check transverse link ball joint axial end play. Refer to [FSU-13, "Removal and Installation"](#).
- Check shock absorber operation.
- Check each mounting part of axle and suspension for looseness and deformation.
- Check each of suspension member, shock absorber, upper link and transverse link for cracks, deformation and other damage.
- Check vehicle height (posture).

GENERAL INFORMATION AND RECOMMENDATIONS

- A four-wheel thrust alignment should be performed.
- This type of alignment is recommended for any NISSAN/INFINITI vehicle.
- The four-wheel “thrust” process helps ensure that the vehicle is properly aligned and the steering wheel is centered.
- The alignment rack itself should be capable of accepting any NISSAN/INFINITI vehicle.
- The rack should be checked to ensure that it is level.
- Make sure the machine is properly calibrated.
- Your alignment equipment should be regularly calibrated in order to give correct information.
- Check with the manufacturer of your specific equipment for their recommended Service/Calibration Schedule.

THE ALIGNMENT PROCESS

IMPORTANT:

Use only the alignment specifications listed in this Service Manual.

- When displaying the alignment settings, many alignment machines use “indicators”: (Green/red, plus or minus, Go/No Go). **Do not use these indicators.**
- The alignment specifications programmed into your machine that operate these indicators may not be correct.
- This may result in an ERROR.
- Some newer alignment machines are equipped with an optional “Rolling Compensation” method to “compensate” the sensors (alignment targets or head units). **Do not use this “Rolling Compensation” method.**

A

B

C

D

FSU

F

G

H

I

J

K

L

M

N

O

P

FRONT SUSPENSION ASSEMBLY

< SERVICE INFORMATION >

[2WD]

- Use the "Jacking Compensation Method". After installing the alignment targets or head units, raise the vehicle and rotate the wheels 1/2 turn both ways.
- See Instructions in the alignment machine you're using for more information on this.

INSPECTION OF CAMBER, CASTER AND KINGPIN INCLINATION ANGLES

- Camber, caster, kingpin inclination angles cannot be adjusted.
- Before inspection, mount front wheels onto turning radius gauge. Mount rear wheels onto a stand that has same height so vehicle will remain horizontal.

FRONT SUSPENSION ASSEMBLY

< SERVICE INFORMATION >

[2WD]

Component

INFOID:000000005347651

A
B
C
D
F
G
H
I
J
K
L
M
N
O
P

FSU

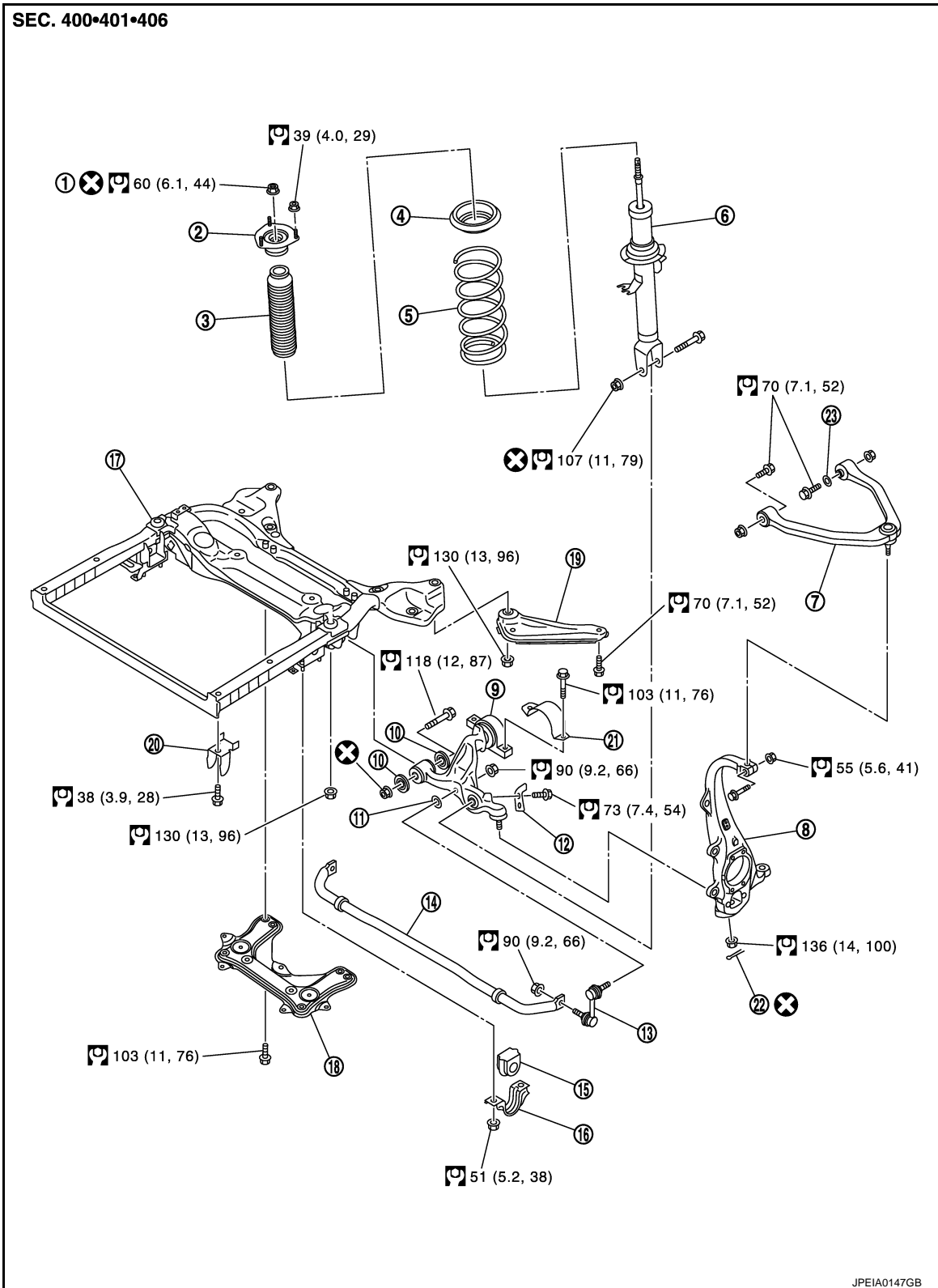

- | | | |
|------------------------|------------------------------------|------------------------------|
| 1. Piston rod lock nut | 2. Shock absorber mounting bracket | 3. Bound bumper |
| 4. Rubber seat | 5. Coil spring | 6. Shock absorber |
| 7. Upper link | 8. Steering knuckle | 9. Transverse link |
| 10. Stopper-arm bush | 11. Washer | 12. Steering stopper bracket |

FRONT SUSPENSION ASSEMBLY

[2WD]

< SERVICE INFORMATION >

- | | | |
|-------------------------------|-----------------------------|------------------------|
| 13. Stabilizer connecting rod | 14. Stabilizer bar | 15. Stabilizer bushing |
| 16. Stabilizer clamp | 17. Front suspension member | 18. Rack stay |
| 19. Member stay | 20. Member bracket | 21. Clamp |
| 22. Cotter pin | 23. Stopper rubber | |

Refer to [GI-9, "Component"](#), for the symbols in the figure.

Removal and Installation

INFOID:000000005347652

REMOVAL

- For VK45DE engine models, disconnect related electric wires and hoses from engine assembly to remove front suspension member with engine assembly. Refer to [EM-238](#).
- Remove cowl top panel and hood. Refer to [EI-29, BL-17, "Removal and Installation of Hood Assembly"](#).
- For VQ35HR engine models, install engine slinger, and then hoist engine. Refer to [EM-108, "2WD : Component"](#).
- Remove tires from vehicle with a power tool.
- Remove wheel sensor from steering knuckle. Refer to [BRC-58](#).
CAUTION:
Do not pull on wheel sensor harness.
- Remove brake hose bracket. Refer to [BR-11](#).
- Remove undercover with a power tool.
- Remove cotter pin (1), and then loosen the nut.
- Remove steering outer socket (2) from steering knuckle (3) so as not to damage ball joint boot (4) using the ball joint remover (suitable tool).
CAUTION:
Temporarily tighten the nut to prevent damage to threads and to prevent the ball joint remover (suitable tool) from suddenly coming off.
- Remove the mounting nut on the upper side of stabilizer connecting rod with a power tool, and then remove stabilizer connecting rod from transverse link.
- Separate steering gear assembly and lower joint. Refer to [PS-12](#).
- Remove rack stay. Refer to [FSU-7, "Component"](#).
- Remove steering hydraulic piping bracket from front suspension member. Refer to [PS-36](#).
- Remove the mounting nut and bolt on the lower side of shock absorber with a power tool, and then remove shock absorber from transverse link.
- Remove cotter pin of transverse link and steering knuckle, and then loosen nut.
- Set jack under front suspension member.
- Remove transverse link from steering knuckle so as not to damage ball joint boot using the ball joint remover (suitable tool)
CAUTION:
Temporarily tighten the nut to prevent damage to threads and to prevent ball joint remover (suitable tool) from suddenly coming off.
- Remove the mounting nuts of engine mounting insulator. Refer to [EM-108, "2WD : Component"](#) (VQ35HR), [EM-238, "2WD : Component"](#) (VK45DE).
- Remove the mounting bolts of member bracket, and then remove member bracket from front suspension member with a power tool. Refer to [FSU-7, "Component"](#).
- Remove the mounting nut and bolts of member stay, and then remove member stay from front suspension member and vehicle with a power tool.
- Remove the mounting nut of front suspension member with a power tool. Refer to [FSU-7, "Component"](#).
- For VQ35HR engine models, gradually lower a jack to remove front suspension assembly from vehicle.

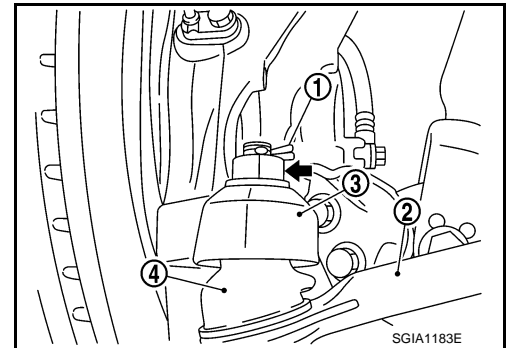

FRONT SUSPENSION ASSEMBLY

< SERVICE INFORMATION >

[2WD]

For VK45DE engine models, gradually lower a jack to remove front suspension assembly with engine assembly from vehicle.

INSTALLATION

- Installation is the reverse order of removal. For tightening torque, refer to [FSU-7. "Component"](#).
- Perform final tightening of each of parts (rubber bushing), under unladen conditions, which were removed when removing front suspension assembly. Check wheel alignment. Refer to [FSU-5. "Wheel Alignment Inspection"](#).
- Adjust neutral position of steering angle sensor after checking wheel alignment. Refer to [BRC-8. "Adjustment of Steering Angle Sensor Neutral Position"](#).
- Check wheel sensor harness for proper connection. Refer to [BRC-58](#).

A
B
C
D
F
G
H
I
J
K
L
M
N
O
P

FSU

COIL SPRING AND SHOCK ABSORBER

< SERVICE INFORMATION >

[2WD]

COIL SPRING AND SHOCK ABSORBER

Removal and Installation

INFOID:000000005347653

REMOVAL

1. Remove tires from vehicle with a power tool.
2. Remove harness of wheel sensor from shock absorber. Refer to [BRC-58](#).
CAUTION:
Do not pull on wheel sensor harness.
3. Remove brake hose bracket. Refer to [BR-11](#).
4. Remove the mounting nut on the upper side of stabilizer connecting rod with a power tool, and then remove stabilizer connecting rod from transverse link.
5. Remove mounting nut and bolt on the lower side of shock absorber with a power tool, and then remove shock absorber from transverse link.
6. Remove cotter pin of transverse link and steering knuckle, and then loosen nut.
7. Remove transverse link from steering knuckle so as not to damage ball joint boot using the ball joint remover (suitable tool).
CAUTION:
Temporarily tighten the nut to prevent damage to threads and to prevent ball joint remover (suitable tool) from suddenly coming off.
8. Remove the mounting nuts of shock absorber mounting bracket, then remove shock absorber from vehicle.

INSTALLATION

- Installation is the reverse order of removal. For tightening torque, refer to [FSU-7. "Component"](#).
- Perform final tightening of bolt and nut at the shock absorber lower side (rubber bushing), under unladen conditions with tires on level ground. Check wheel alignment. Refer to [FSU-5. "Wheel Alignment Inspection"](#).
- Adjust neutral position of steering angle sensor after checking wheel alignment. Refer to [BRC-8. "Adjustment of Steering Angle Sensor Neutral Position"](#).
- Check wheel sensor harness for proper connection. Refer to [BRC-58](#).

Disassembly and Assembly

INFOID:000000005347654

DISASSEMBLY

CAUTION:

Do not damage shock absorber piston rod when removing components from shock absorber.

1. Install shock absorber attachment [SST] to shock absorber and secure it in a vise.

CAUTION:

When installing the shock absorber attachment to shock absorber, wrap a shop cloth around strut to protect it from damage.

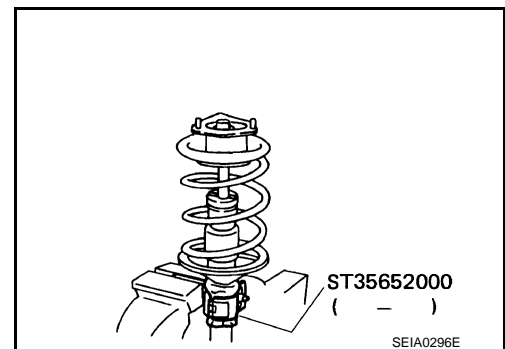

COIL SPRING AND SHOCK ABSORBER

[2WD]

< SERVICE INFORMATION >

- Using a spring compressor (commercial service tool), compress coil spring between rubber seat and spring lower seat (on shock absorber) until coil spring with a spring compressor is free.

CAUTION:

Be sure a spring compressor is securely attached coil spring. Compress coil spring

- Make sure coil spring with a spring compressor between rubber seat and spring lower seat (shock absorber) is free and then remove piston rod lock nut while securing the piston rod tip so that piston rod does not turn.
- Remove shock absorber mounting bracket, rubber seat, bound bumper from shock absorber.
- Remove coil spring with a spring compressor, and then gradually release a spring compressor.

CAUTION:

Loosen while making sure coil spring attachment position does not move.

- Remove the shock absorber attachment from shock absorber.

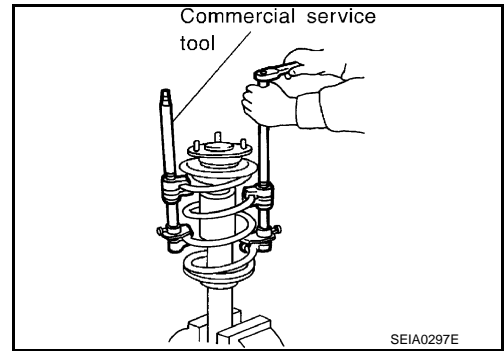

INSPECTION AFTER DISASSEMBLY

Shock Absorber Inspection

Check the following:

- Shock absorber for deformation, cracks or damage, and replace it if a malfunction is detected.
- Piston rod for damage, uneven wear or distortion, and replace it if a malfunction is detected.
- For oil leakage, and replace it if a malfunction is detected.

Shock Absorber Mounting Bracket and Rubber Parts Inspection

Check shock absorber mounting bracket for cracks and rubber parts for wear. Replace it if a malfunction is detected.

Coil Spring Inspection

Check coil spring for cracks, wear or damage, and replace it if a malfunction is detected.

ASSEMBLY

CAUTION:

Do not damage shock absorber piston rod when installing components to shock absorber.

- Install shock absorber attachment [SST] to shock absorber and secure it in a vise.

CAUTION:

When installing the shock absorber attachment to shock absorber, wrap a shop cloth around strut to protect it from damage.

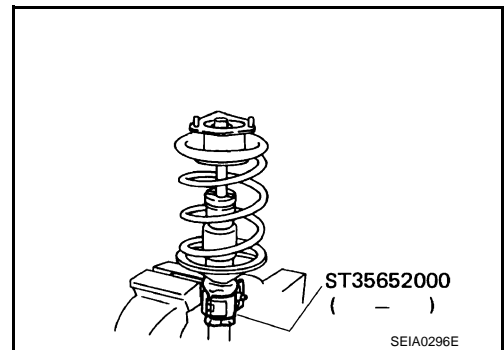

- Compress coil spring using a spring compressor (commercial service tool), and install it onto shock absorber.

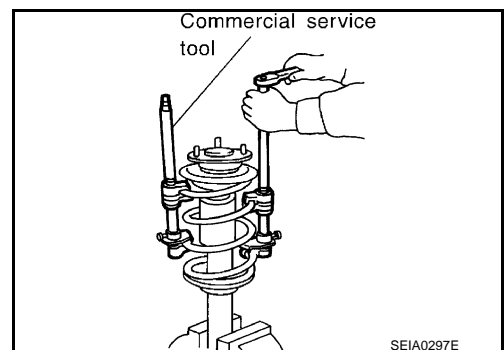

CAUTION:

A
B
C
D
F
G
H
I
J
K
L
M
N
O
P

FSU

COIL SPRING AND SHOCK ABSORBER

< SERVICE INFORMATION >

[2WD]

- Install coil spring as shown in the figure with large diameter side [100 mm (3.94 in)] up and small diameter side [90 mm (3.54 in)] down. (Distinction marks are 4.75 and 5.75 turn from the lower side end.)
 - Be sure a spring compressor is securely attached to coil spring. Compress coil spring.
3. Apply soapy water to bound bumper. Insert bound bumper into shock absorber mounting bracket, and then install it to shock absorber together with rubber seat.

CAUTION:
Do not use machine oil.

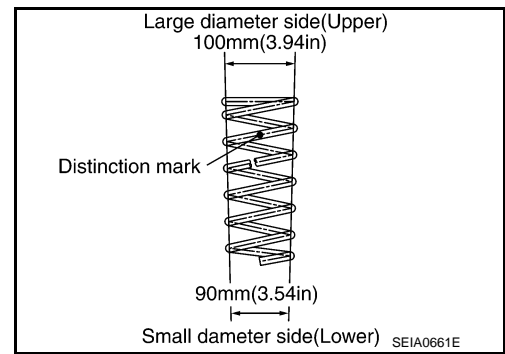

- Install shock absorber mounting bracket as shown in the figure.
- CAUTION:**
- Coil spring is securely seated in spring mounting groove of rubber seat.
 - The bottom part of spring should be at the position of A point of spring seat.
4. Secure piston rod tip so that piston rod does not turn, then tighten piston rod lock nut with specified torque.
 5. Gradually release a spring compressor, and remove coil spring.

CAUTION:
Loosen while making sure coil spring attachment position does not move.
 6. Remove the shock absorber attachment from shock absorber.

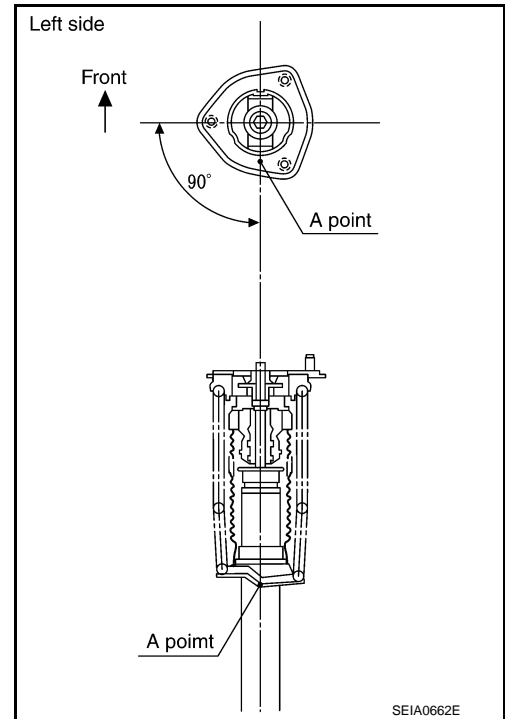

Disposal

INFOID:000000005488870

1. Set shock absorber horizontally with the piston rod fully extended.
2. Drill 2 – 3 mm (0.08 – 0.12 in) hole at the position (●) from top as shown in the figure to release gas gradually.

CAUTION:

- Wear eye protection (safety glasses).
- Wear gloves.
- Be careful with metal chips or oil blown out by the compressed gas.

NOTE:

- Drill vertically in this direction (←).
- Directly to the outer tube avoiding brackets.
- The gas is clear, colorless, odorless, and harmless.

A : 20 – 30 mm (0.79 – 1.18 in)

3. Position the drilled hole downward and drain oil by moving the piston rod several times.

CAUTION:

Dispose of drained oil according to the law and local regulations.

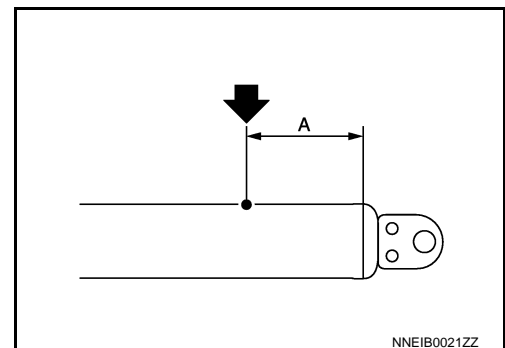

TRANSVERSE LINK

Removal and Installation

INFOID:000000005347655

REMOVAL

1. Remove tires from vehicle with a power tool.
2. Remove undercover with a power tool.
3. Remove the mounting nut on the upper side of stabilizer connecting rod with a power tool, and then remove stabilizer connecting rod from transverse link.
4. Separate steering gear assembly and lower joint. Refer to [PS-12](#).
5. Remove rack stay. Refer to [FSU-7, "Component"](#).
6. Remove the mounting nut and bolt on the lower side of shock absorber with a power tool, and then remove shock absorber from transverse link.
7. Remove transverse link from steering knuckle. Refer to [FSU-7, "Component"](#).
8. Set jack under front suspension member.
9. Remove the mounting bolts of member bracket, and then remove member bracket from front suspension member with a power tool. Refer to [FSU-7, "Component"](#).
10. Remove the mounting nut and bolts of member stay, and then remove member stay from front suspension member and vehicle with a power tool.
11. Remove the mounting nut of front suspension member with a power tool. Refer to [FSU-7, "Component"](#).
12. Gradually lower the suspension member to the position where transverse link mounting bolts is remove.
CAUTION:
Be careful not to lower it too far. (Do not overload the links)
13. Remove mounting nut and bolts and stopper-arm bush, and then remove transverse link from vehicle.

INSPECTION AFTER REMOVAL

Visual Inspection

- Check transverse link and bushing for deformation, cracks or damage. Replace it if a malfunction is detected.
- Check ball joint boot for cracks or other damage, and also for grease leakage. Replace it if a malfunction is detected.

Ball Joint Inspection

Manually move ball stud to confirm it moves smoothly with no binding.

Swing Torque Inspection

NOTE:

Before measurement, move ball stud at least ten times by hand to check for smooth movement.

- Hook a spring balance at cotter pin mounting hole. Confirm spring balance measurement value is within specifications when ball stud begins moving.

Swing torque

: 0.5 - 3.6 N·m (0.06 - 0.36 kg·m, 5 - 31 in·lb)

Spring balance measurement

: 7.8 - 56.3 N (0.8 - 5.7 kg, 1.8 - 12.5 lb)

- If it is outside the specified range, replace transverse link assembly.

Rotating Torque Inspection

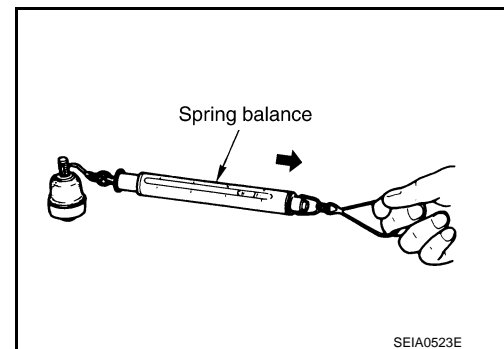

TRANSVERSE LINK

[2WD]

< SERVICE INFORMATION >

- Attach mounting nut to ball stud. Make sure that rotating torque is within specifications with a preload gauge [SST].

Rotating torque

: 0.5 - 3.9 N·m (0.06 - 0.39 kg·m, 5 - 34 in·lb)

- If it is outside the specified range, replace transverse link assembly.

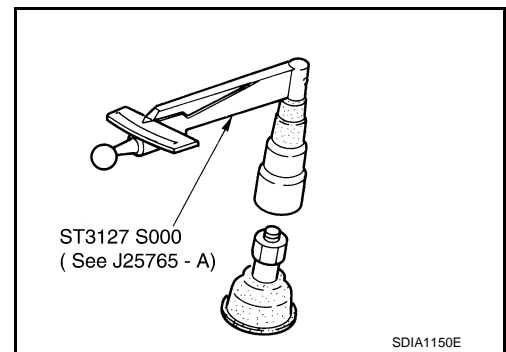

Axial End Play Inspection

- Move tip of ball stud in axial direction to check for looseness.

Axial end play : 0 mm (0 in)

- If it is outside the specified range, replace transverse link assembly.

INSTALLATION

- Installation is the reverse order of removal. For tightening torque, refer to [FSU-7, "Component"](#).
- Perform final tightening of bolts and nuts at the front suspension member installation position and the shock absorber lower side (rubber bushing) under unladen conditions with tires on level ground. Check wheel alignment. Refer to [FSU-5, "Wheel Alignment Inspection"](#).
- Adjust neutral position of steering angle sensor after checking wheel alignment. Refer to [BRC-8, "Adjustment of Steering Angle Sensor Neutral Position"](#).

UPPER LINK

Removal and Installation

INFOID:000000005347656

REMOVAL

1. Remove tires from vehicle with a power tool.
2. Remove shock absorber. Refer to [FSU-10](#).
3. Remove mounting nut and bolt with a power tool, and then remove upper link from steering knuckle.
4. Remove mounting nuts and bolts, and then remove upper link and stopper rubber from vehicle.

INSPECTION AFTER REMOVAL

Visual Inspection

Check the following:

- Upper link and bushing for deformation, cracks or damage. Replace it if a malfunction is detected.
- Ball joint boot for cracks or other damage, and also for grease leakage. Replace it if a malfunction is detected.

Ball Joint Inspection

Manually move ball stud to confirm it moves smoothly with no binding.

Swing Torque Inspection

NOTE:

Before measurement, move ball stud at least ten times by hand to check for smooth movement.

- Hook a spring balance at cutout on ball stud. Confirm spring balance measurement value is within specifications when ball stud begins moving.

Swing torque**: 0 - 2.0 N·m (0 - 0.2 kg·m, 0 - 17 in·lb)****Spring balance measurement****: 0 - 61.5 N (0 - 6.2 kg, 0 - 13.6 lb)**

- If it is outside the specified range, replace upper link assembly.

Axial End Play Inspection

- Move tip of ball stud in axial direction to check for looseness.

Axial end play : 0 mm (0 in)

- If it is outside the specified range, replace upper link assembly.

INSTALLATION

- Installation is the reverse order of removal. For tightening torque, refer to [FSU-7, "Component"](#).
- Perform final tightening of bolts and nuts at the vehicle installation position (rubber bushing) under unladen conditions with tires on level ground. Check wheel alignment. Refer to [FSU-5, "Wheel Alignment Inspection"](#).
- Adjust neutral position of steering angle sensor after checking wheel alignment. Refer to [BRC-8, "Adjustment of Steering Angle Sensor Neutral Position"](#).

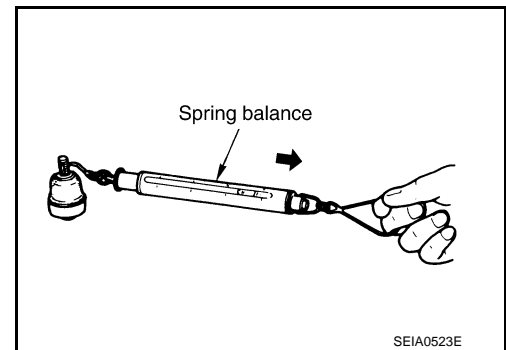

STABILIZER BAR

Removal and Installation

INFOID:000000005347657

REMOVAL

1. Remove tires from vehicle with a power tool.
2. Remove undercover with a power tool.
3. Remove the mounting nut on the lower side of stabilizer connecting rod with a power tool, and then remove stabilizer connecting rod from stabilizer bar.
4. If necessary remove the mounting nut on the upper side of stabilizer connecting rod with a power tool, and then remove stabilizer connecting rod from transverse link.
5. Remove the mounting nuts of stabilizer clamp, and then remove stabilizer clamp and stabilizer bushing.
6. Remove stabilizer bar from vehicle.

INSPECTION AFTER REMOVAL

Check stabilizer bar, stabilizer connecting rod, stabilizer bushing and stabilizer clamp for deformation, cracks or damage. Replace it if a malfunction is detected.

INSTALLATION

Installation is the reverse order of removal. For tightening torque, refer to [FSU-7, "Component"](#).

SERVICE DATA AND SPECIFICATIONS (SDS)

< SERVICE INFORMATION >

[2WD]

SERVICE DATA AND SPECIFICATIONS (SDS)

Wheel Alignment (Unladen *)

INFOID:000000005347658

Item		Standard		
Tire size		245/45R18	245/40R19	
Camber Degree minute (Decimal degree)	Minimum	-1° 00' (-1.00°)		
	Nominal	-0° 15' (-0.25°)		
	Maximum	0° 30' (0.50°)		
	Left and right difference	33' (0.55°) or less		
Caster Degree minute (Decimal degree)	Minimum	3° 45' (3.75°)	3° 50' (3.84°)	
	Nominal	4° 30' (4.50°)	4° 35' (4.58°)	
	Maximum	5° 15' (5.25°)	5° 20' (5.33°)	
	Left and right difference	39' (0.65°) or less		
Kingpin inclination Degree minute (Decimal degree)	Minimum	6° 30' (6.50°)		
	Nominal	7° 15' (7.25°)		
	Maximum	8° 00' (8.00°)		
Total toe-in	Distance	Minimum	0 mm (0 in)	
		Nominal	In 1 mm (0.04 in)	
		Maximum	In 2 mm (0.08 in)	
	Angle (left wheel or right wheel) Degree minute (Decimal degree)	Minimum	0° 00' (0.00°)	
		Nominal	In 0° 03' (0.05°)	
		Maximum	In 0° 06' (0.10°)	

*: Fuel, engine coolant and lubricant are full. Spare tire, jack, hand tools and mats are in designated positions.

Ball Joint

INFOID:000000005347659

Item		Standard	
Swing torque	Transverse link	0.5 – 3.6 N·m (0.06 – 0.36 kg·m, 5 – 31 in-lb)	
	Upper link	0 – 2.0 N·m (0 – 0.2 kg·m, 0 – 17 in-lb)	
Measurement on spring balance	Transverse link	7.8 – 56.3 N (0.8 – 5.7 kg, 1.8 – 12.5 lb)	
	Upper link	0 – 61.5 N (0 – 6.2 kg, 0 – 13.6 lb)	
Rotating torque	Transverse link	0.5 – 3.9 N·m (0.06 – 0.39 kg·m, 5 – 34 in-lb)	
Axial end play		0 mm (0 in)	

Wheelarch Height (Unladen*)

INFOID:000000005347660

U.S.A. model

Item	Standard	
Tire size	245/45R18	245/40R19
Front (Hf)	717 mm (28.23 in)	721 mm (28.39 in)

SERVICE DATA AND SPECIFICATIONS (SDS)

< SERVICE INFORMATION >

[2WD]

Item	Standard	
Tire size	245/45R18	245/40R19
Rear (Hr)	710 mm (27.95 in)	711 mm (27.99 in)

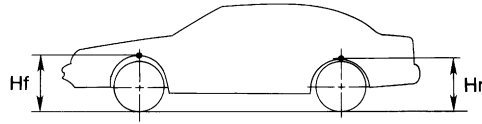

SFA818A

Canada model

Item	Standard	
Tire size	245/45R18	245/40R19
Front (Hf)	718 mm (28.27 in)	721 mm (28.39 in)
Rear (Hr)	711 mm (27.99 in)	711 mm (27.99 in)

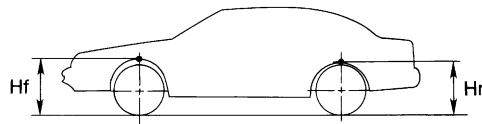

SFA818A

SERVICE INFORMATION

PRECAUTIONS

Caution

INFOID:000000005347661

- When installing rubber bushings, the final tightening must be carried out under unladen conditions with tires on ground. Oil might shorten the life of rubber bushings. Be sure to wipe off any spilled oil.
- Unladen conditions mean that fuel, engine coolant and lubricant are full. Spare tire, jack, hand tools and mats are in designated positions.
- After servicing suspension parts, be sure to check wheel alignment.
- Self-lock nuts are not reusable. Always use new ones when installing. Since new self-lock nuts are pre-oiled, tighten as they are.

A
B
C
D
F
G
H
I
J
K
L
M
N
O
P



PREPARATION

< SERVICE INFORMATION >

[AWD]

PREPARATION

Special Service Tool

INFOID:000000005347662

The actual shapes of Kent-Moore tools may differ from those of special service tools illustrated here.

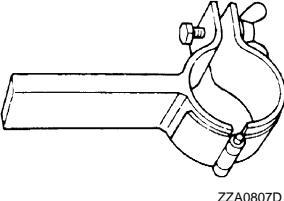
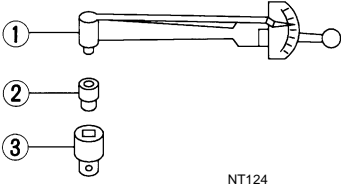
Tool number (Kent-Moore No.) Tool name	Description	
ST35652000 (—) Shock absorber attachment	 <p style="text-align: center;">ZZA0807D</p>	Disassembling and assembling shock absorber
ST3127S000 (See J-25765-A) Preload Gauge 1. GG91030000 (J-25765-A) Torque wrench 2. HT62940000 (—) Socket adapter 3. HT62900000 (—) Socket adapter	 <p style="text-align: center;">NT124</p>	Measuring rotating torque of ball joint

Commercial Service Tool

INFOID:000000005347663

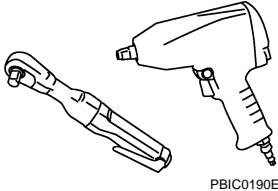
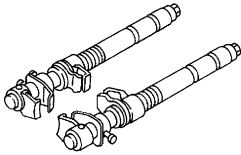
Tool name	Description	
Power tool	 <p style="text-align: center;">PBIC0190E</p> <ul style="list-style-type: none"> • Removing wheel nuts • Removing torque member fixing bolts • Removing undercover • Removing front suspension components parts • Removing hub lock nut 	
Spring compressor	 <p style="text-align: center;">S-NT717</p>	Removing and installing coil spring

NOISE, VIBRATION AND HARSHNESS (NVH) TROUBLESHOOTING

< SERVICE INFORMATION >

[AWD]

NOISE, VIBRATION AND HARSHNESS (NVH) TROUBLESHOOTING

NVH Troubleshooting Chart

INFOID:000000005347664

Use chart below to find the cause of the symptom. If necessary, repair or replace these parts.

Reference page		FSU-24	FSU-27	—	—	—	FSU-24	FSU-22	FSU-33	NVH in PR section	NVH in RFD section	NVH in FAX and FSU section	NVH in WT section	NVH in FAX section	NVH in BR section	NVH in PS section		
Possible cause and SUSPECTED PARTS		Improper installation, looseness	Strut deformation, damage or deflection	Bushings or mounting deterioration	Parts interference	Spring fatigue	Suspension looseness	Incorrect wheel alignment	Stabilizer bar fatigue	PROPELLER SHAFT	DIFFERENTIAL	FRONT AXLE AND FRONT SUSPENSION	ROAD WHEEL	DRIVE SHAFT	BRAKES	STEERING		
Symptom	FRONT SUSPENSION	Noise	x	x	x	x	x	x	x	x	x	x	x	x	x	x		
		Shake	x	x	x	x	x	x	x	x	x	x	x	x	x	x	x	
		Vibration	x	x	x	x	x	x	x	x	x	x	x	x	x	x	x	
		Shimmy	x	x	x	x	x	x	x	x	x	x	x	x	x	x	x	x
		Judder	x	x	x	x	x	x	x	x	x	x	x	x	x	x	x	x
		Poor quality ride or handling	x	x	x	x	x	x	x	x	x	x	x	x	x	x	x	x

x: Applicable

A
B
C
D
FSU
F
G
H
I
J
K
L
M
N
O
P

FRONT SUSPENSION ASSEMBLY

< SERVICE INFORMATION >

[AWD]

FRONT SUSPENSION ASSEMBLY

On-Vehicle Inspection

INFOID:000000005347665

Make sure the mounting conditions (looseness, back lash) of each component and component conditions (wear, damage) are normal.

INSPECTION OF UPPER LINK BALL JOINT END PLAY

1. Set front wheels in a straight-ahead position. Do not depress brake pedal.
2. Place an iron bar or similar tool between transverse link and steering knuckle.
3. Measure axial end play by prying it up and down.

Axial end play : 0 mm (0 in)

CAUTION:

Be careful not to damage ball joint boot. Do not damage the installation position by applying excessive force.

SHOCK ABSORBER INSPECTION

Check for oil leakage, damage and breakage of installation positions.

Wheel Alignment Inspection

INFOID:000000005347666

DESCRIPTION

Measure wheel alignment under unladen conditions.

NOTE:

“Unladen conditions” means that fuel, engine coolant, and lubricant are full. Spare tire, jack, hand tools and mats are in designated positions.

PRELIMINARY CHECK

Check the following:

1. Check tires for improper air pressure and wear.
2. Check road wheels for runout. Refer to [WT-8](#).
3. Check wheel bearing axial end play. Refer to [FAX-6, "On-Vehicle Inspection"](#).
4. Check transverse link ball joint axial end play. Refer to [FSU-30, "Removal and Installation"](#).
5. Check shock absorber operation.
6. Check each mounting part of axle and suspension for looseness and deformation.
7. Check each of suspension member, shock absorber, upper link and transverse link for cracks, deformation and other damage.
8. Check vehicle height (posture).

GENERAL INFORMATION AND RECOMMENDATIONS

- A four-wheel thrust alignment should be performed.
- This type of alignment is recommended for any NISSAN/INFINITI vehicle.
- The four-wheel “thrust” process helps ensure that the vehicle is properly aligned and the steering wheel is centered.
- The alignment rack itself should be capable of accepting any NISSAN/INFINITI vehicle.
- The rack should be checked to ensure that it is level.
- Make sure the machine is properly calibrated.
- Your alignment equipment should be regularly calibrated in order to give correct information.
- Check with the manufacturer of your specific equipment for their recommended Service/Calibration Schedule.

THE ALIGNMENT PROCESS

IMPORTANT:

Use only the alignment specifications listed in this Service Manual.

- When displaying the alignment settings, many alignment machines use “indicators”: (Green/red, plus or minus, Go/No Go). **Do not use these indicators.**
- The alignment specifications programmed into your machine that operate these indicators may not be correct.

FRONT SUSPENSION ASSEMBLY

[AWD]

< SERVICE INFORMATION >

- This may result in an ERROR.
- Some newer alignment machines are equipped with an optional “Rolling Compensation” method to “compensate” the sensors (alignment targets or head units). **DO not use this “Rolling Compensation” method.**
- Use the “Jacking Compensation Method”. After installing the alignment targets or head units, raise the vehicle and rotate the wheels 1/2 turn both ways.
- See Instructions in the alignment machine you're using for more information on this.

INSPECTION OF CAMBER, CASTER AND KINGPIN INCLINATION ANGLES

- Camber, caster, kingpin inclination angles cannot be adjusted.
- Before inspection, mount front wheels onto turning radius gauge. Mount rear wheels onto a stand that has same height so vehicle will remain horizontal.

A
B
C
D
E
F
G
H
I
J
K
L
M
N
O
P

FSU

FRONT SUSPENSION ASSEMBLY

< SERVICE INFORMATION >

[AWD]

Component

INFOID:000000005347667

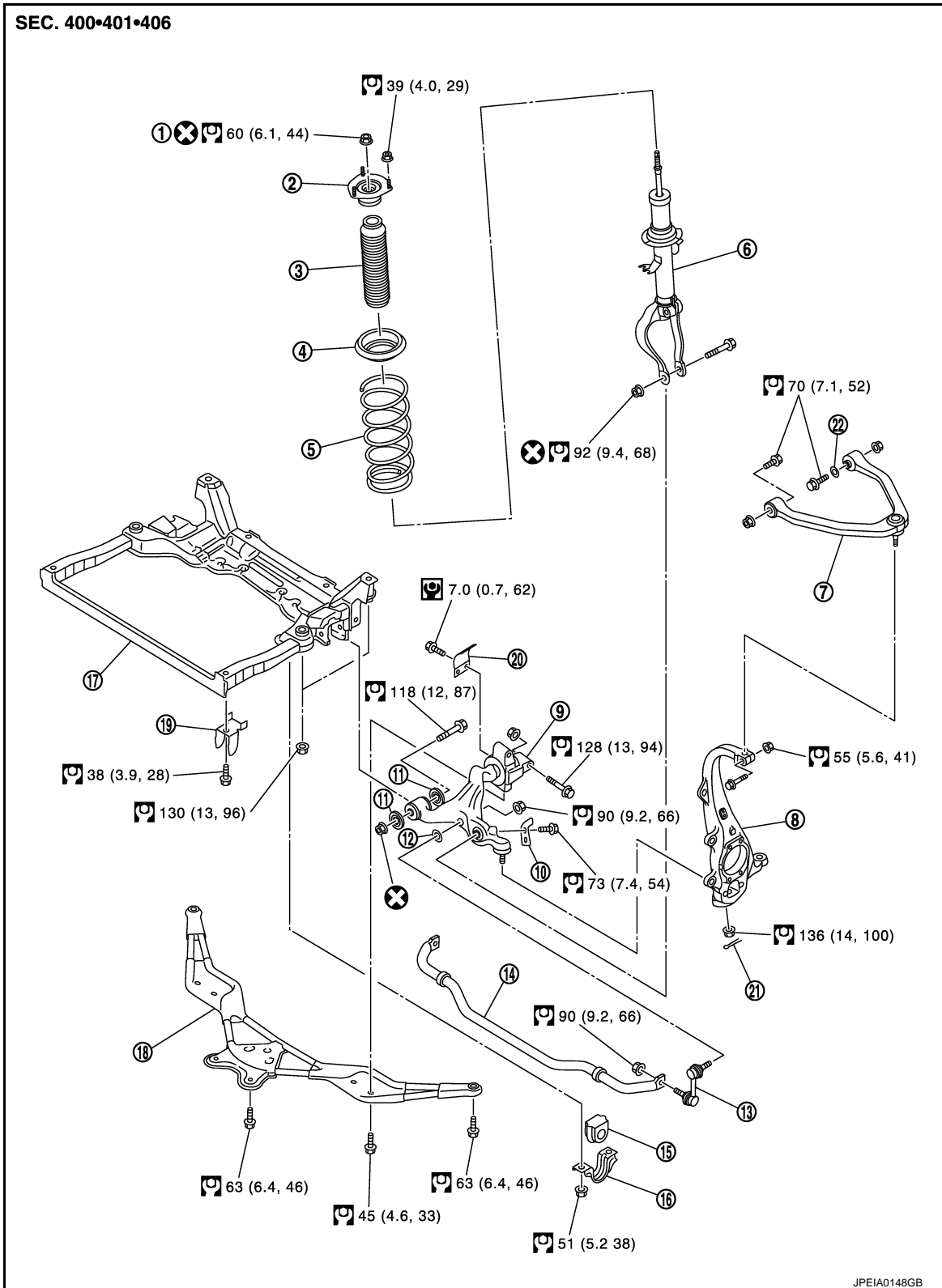

FRONT SUSPENSION ASSEMBLY

[AWD]

< SERVICE INFORMATION >

- | | | |
|-------------------------------|-----------------------------|------------------------|
| 13. Stabilizer connecting rod | 14. Stabilizer bar | 15. Stabilizer bushing |
| 16. Stabilizer clamp | 17. Front suspension member | 18. Front cross bar |
| 19. Member bracket | 20. Clamp | 21. Cotter pin |
| 22. Stopper rubber | | |

Refer to [GI-9, "Component"](#), for the symbols in the figure.

Removal and Installation

INFOID:000000005347668

REMOVAL

1. Remove cowl top panel and hood. Refer to [EI-29, BL-17, "Removal and Installation of Hood Assembly"](#).
2. Install engine slinger, and then hoist engine. Refer to [EM-113, "AWD : Component" \(VQ35HR\)](#), [EM-242, "AWD : Component" \(VK45DE\)](#).
3. Remove tires from vehicle with a power tool.
4. Remove wheel sensor from steering knuckle. Refer to [BRC-58](#).
CAUTION:
Do not pull on wheel sensor harness.
5. Remove brake hose bracket. Refer to [BR-11](#).
6. Remove undercover with a power tool.
7. Remove cotter pin (1), and then loosen the nut.
8. Remove steering outer socket (2) from steering knuckle (3) so as not to damage ball joint boot (4) using the ball joint remover (suitable tool).
CAUTION:
Temporarily tighten the nut to prevent damage to threads and to prevent the ball joint remover (suitable tool) from suddenly coming off.
9. Remove the mounting nut on the upper side of stabilizer connecting rod with a power tool, and then remove stabilizer connecting rod from transverse link.
10. Separate steering gear assembly and lower joint. Refer to [PS-12](#).
11. Remove front cross bar. Refer to [FSU-24, "Component"](#).
12. Remove steering hydraulic piping bracket from front suspension member. Refer to [PS-36](#).
13. Remove the mounting nut and bolt on the lower side of shock absorber arm with a power tool, and then remove shock absorber arm from transverse link.
14. Remove cotter pin of transverse link and steering knuckle, and then loosen nut.
15. Remove transverse link from steering knuckle so as not to damage ball joint boot using the ball joint remover (suitable tool).
CAUTION:
Temporarily tighten the nut to prevent damage to threads and to prevent ball joint remover (suitable tool) from suddenly coming off.
16. Set jack under front suspension member.
17. Remove the mounting nuts of engine mounting insulator. Refer to [EM-113, "AWD : Component" \(VQ35HR\)](#), [EM-242, "AWD : Component" \(VK45DE\)](#).
18. Remove the mounting bolts of member bracket, and then remove member bracket from front suspension member with a power tool. Refer to [FSU-24, "Component"](#).
19. Remove the mounting nuts of front suspension member with a power tool. Refer to [FSU-24, "Component"](#).
20. Gradually lower a jack to remove front suspension assembly from vehicle.

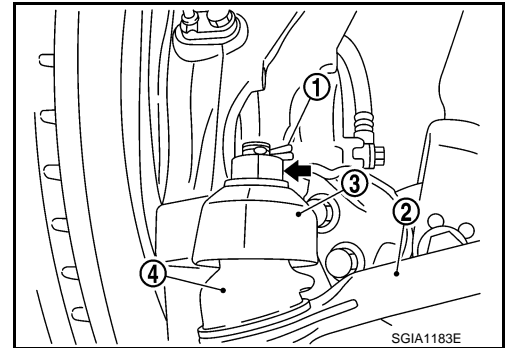

INSTALLATION

- Installation is the reverse order of removal. For tightening torque, refer to [FSU-24, "Component"](#).
- Perform final tightening of each of parts (rubber bushing), under unladen conditions, which were removed when removing front suspension assembly. Check wheel alignment. Refer to [FSU-22, "Wheel Alignment Inspection"](#).

FRONT SUSPENSION ASSEMBLY

[AWD]

< SERVICE INFORMATION >

- Adjust neutral position of steering angle sensor after checking wheel alignment. Refer to [BRC-8. "Adjustment of Steering Angle Sensor Neutral Position"](#).
- Check wheel sensor harness for proper connection. Refer to [BRC-58](#).

COIL SPRING AND SHOCK ABSORBER

< SERVICE INFORMATION >

[AWD]

COIL SPRING AND SHOCK ABSORBER

Removal and Installation

INFOID:000000005347669

REMOVAL

1. Remove tires from vehicle with a power tool.
2. Remove harness of wheel sensor from shock absorber. Refer to [BRC-58](#).
CAUTION:
Do not pull on wheel sensor harness.
3. Remove brake hose bracket. Refer to [BR-11](#).
4. Remove the mounting nut on the upper side of stabilizer connecting rod with a power tool, and then remove stabilizer connecting rod from transverse link.
5. Remove mounting nut and bolt on the lower side of shock absorber arm with a power tool, and then remove shock absorber arm from transverse link.
6. Remove cotter pin of transverse link and steering knuckle, and then loosen nut.
7. Remove transverse link from steering knuckle so as not to damage ball joint boot using the ball joint remover (suitable tool).
CAUTION:
Temporarily tighten the nut to prevent damage to threads and to prevent ball joint remover (suitable tool) from suddenly coming off.
8. Remove the mounting bolt on the upper side of shock absorber arm with a power tool, and then remove shock absorber arm from shock absorber.
9. Remove the mounting nuts of shock absorber mounting bracket, then remove shock absorber from vehicle.

INSTALLATION

- Installation is the reverse order of removal. For tightening torque, refer to [FSU-24, "Component"](#).
- Perform final tightening of bolt and nut at the shock absorber arm lower side (rubber bushing) under unladen conditions with tires on level ground. Check wheel alignment. Refer to [FSU-22, "Wheel Alignment Inspection"](#).
- Adjust neutral position of steering angle sensor after checking wheel alignment. Refer to [BRC-8, "Adjustment of Steering Angle Sensor Neutral Position"](#).
- Check wheel sensor harness for proper connection. Refer to [BRC-58](#).

Disassembly and Assembly

INFOID:000000005347670

DISASSEMBLY

CAUTION:

Do not damage shock absorber piston rod when removing components from shock absorber.

1. Install shock absorber attachment [SST] to shock absorber and secure it in a vise.

CAUTION:

When installing the shock absorber attachment to shock absorber, wrap a shop cloth around strut to protect it from damage.

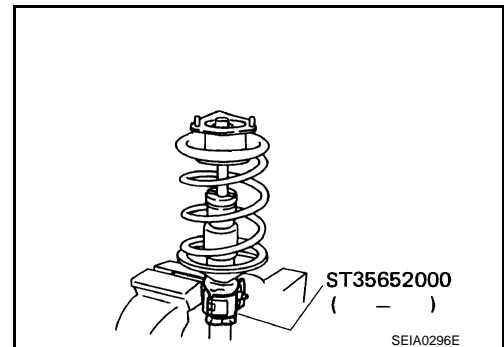

COIL SPRING AND SHOCK ABSORBER

[AWD]

< SERVICE INFORMATION >

- Using a spring compressor (commercial service tool), compress coil spring between rubber seat and spring lower seat (on shock absorber) until coil spring with a spring compressor is free.

CAUTION:

Be sure a spring compressor is securely attached coil spring. Compress coil spring

- Make sure coil spring with a spring compressor between rubber seat and spring lower seat (shock absorber) is free and then remove piston rod lock nut while securing the piston rod tip so that piston rod does not turn.
- Remove shock absorber mounting bracket, rubber seat, bound bumper from shock absorber.
- Remove coil spring with a spring compressor, and then gradually release a spring compressor.

CAUTION:

Loosen while making sure coil spring attachment position does not move.

- Remove the shock absorber attachment from shock absorber.

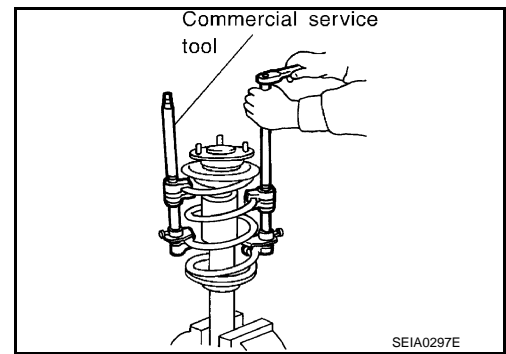

INSPECTION AFTER DISASSEMBLY

Shock Absorber Inspection

Check the following:

- Shock absorber for deformation, cracks or damage, and replace it if a malfunction is detected.
- Piston rod for damage, uneven wear or distortion, and replace it if a malfunction is detected.
- For oil leakage, and replace it if a malfunction is detected.

Shock Absorber Mounting Bracket and Rubber Parts Inspection

Check shock absorber mounting bracket for cracks and rubber parts for wear. Replace it if a malfunction is detected

Coil Spring Inspection

Check coil spring for cracks, wear or damage, and replace it if a malfunction is detected.

ASSEMBLY

CAUTION:

Do not damage shock absorber piston rod when installing components to shock absorber.

- Install shock absorber attachment [SST] to shock absorber and secure it in a vise.

CAUTION:

When installing the shock absorber attachment to shock absorber, wrap a shop cloth around strut to protect it from damage.

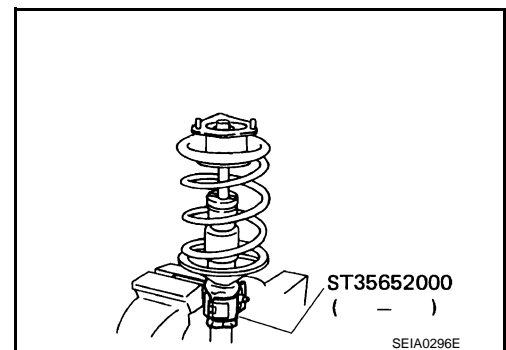

- Compress coil spring using a spring compressor (commercial service tool), and install it onto shock absorber.

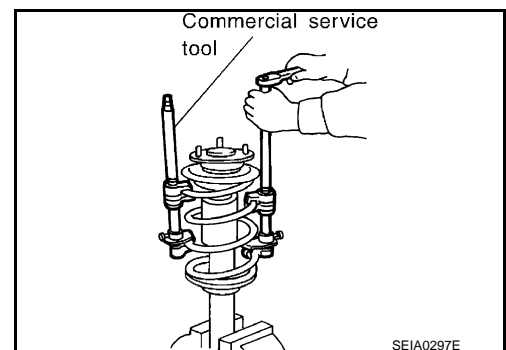

CAUTION:

COIL SPRING AND SHOCK ABSORBER

[AWD]

< SERVICE INFORMATION >

- Install coil spring as shown in the figure with large diameter side [100 mm (3.94 in)] up and small diameter side [90 mm (3.54 in)] down. (Distinction marks are 4.75 and 5.75 turn from the lower side end.)
- Be sure a spring compressor is securely attached to coil spring. Compress coil spring.

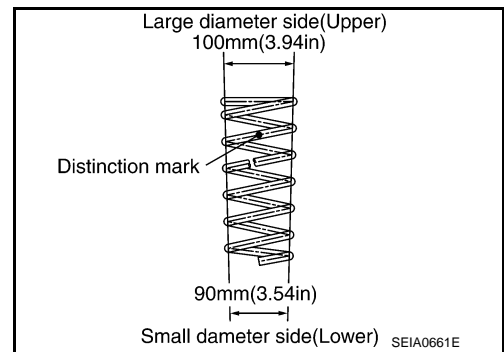

3. Apply soapy water to bound bumper. Insert bound bumper into shock absorber mounting bracket, and then install it to shock absorber together with rubber seat.

CAUTION:

Do not use machine oil.

- Install shock absorber mounting bracket as shown in the figure.

CAUTION:

- **Coil spring is securely seated in spring mounting groove of rubber seat.**
- **The bottom part of spring should be at the position of A point of spring seat.**

4. Secure piston rod tip so that piston rod does not turn, then tighten piston rod lock nut with specified torque.

5. Gradually release a spring compressor, and remove coil spring.

CAUTION:

Loosen while making sure coil spring attachment position does not move.

6. Remove the shock absorber attachment from shock absorber.

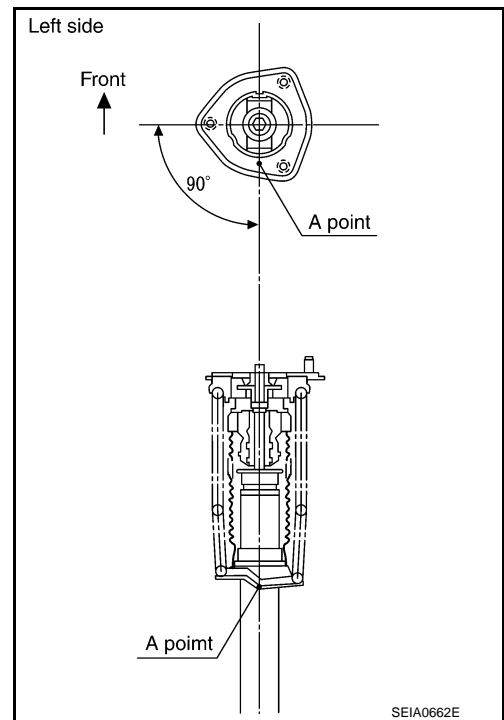

Disposal

INFOID:000000005488875

1. Set shock absorber horizontally with the piston rod fully extended.
2. Drill 2 – 3 mm (0.08 – 0.12 in) hole at the position (●) from top as shown in the figure to release gas gradually.

CAUTION:

- **Wear eye protection (safety glasses).**
- **Wear gloves.**
- **Be careful with metal chips or oil blown out by the compressed gas.**

NOTE:

- Drill vertically in this direction (←).
- Directly to the outer tube avoiding brackets.
- The gas is clear, colorless, odorless, and harmless.

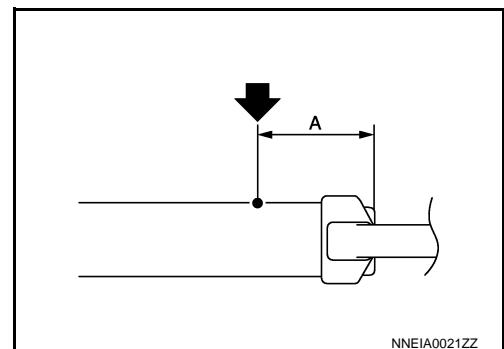

A : 20 – 30 mm (0.79 – 1.18 in)

3. Position the drilled hole downward and drain oil by moving the piston rod several times.

CAUTION:

Dispose of drained oil according to the law and local regulations.

TRANSVERSE LINK

Removal and Installation

INFOID:000000005347671

REMOVAL

1. Remove tires from vehicle with a power tool.
2. Remove undercover with a power tool.
3. Remove the mounting nut on the upper side of stabilizer connecting rod with a power tool, and then remove stabilizer connecting rod from transverse link.
4. Remove the mounting nut and bolt on the lower side of shock absorber arm with a power tool, and then remove shock absorber arm from transverse link.
5. Remove front cross bar. Refer to [FSU-24, "Component"](#).
6. Remove transverse link from steering knuckle. Refer to [FSU-24, "Component"](#).
7. Remove mounting nuts and bolts and stopper-arm bush, and then remove transverse link from vehicle.

INSPECTION AFTER REMOVAL

Visual Inspection

Check the following:

- Transverse link and bushing for deformation, cracks or damage. Replace it if a malfunction is detected.
- Ball joint boot for cracks or other damage, and also for grease leakage. Replace it if a malfunction is detected.

Ball Joint Inspection

Manually move ball stud to confirm it moves smoothly with no binding.

Swing Torque Inspection

NOTE:

Before measurement, move ball stud at least ten times by hand to check for smooth movement.

- Hook a spring balance at cotter pin mounting hole. Confirm spring balance measurement value is within specifications when ball stud begins moving.

Swing torque

: 0.5 - 3.6 N-m (0.06 - 0.36 kg-m, 5 - 31 in-lb)

Spring balance measurement

: 7.8 - 56.3 N (0.8 - 5.7 kg, 1.8 - 12.5 lb)

- If it is outside the specified range, replace transverse link assembly.

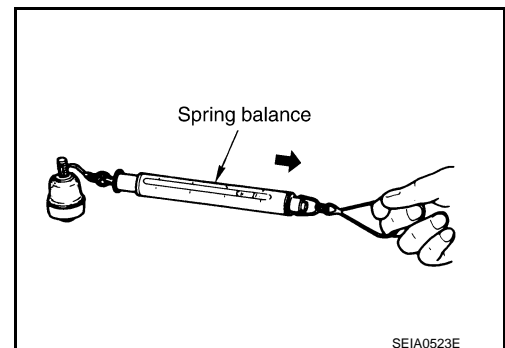

Rotating Torque Inspection

- Attach mounting nut to ball stud. Make sure that rotating torque is within specifications with a preload gauge [SST].

Rotating torque

: 0.5 - 3.9 N-m (0.06 - 0.39 kg-m, 5 - 34 in-lb)

- If it is outside the specified range, replace transverse link assembly.

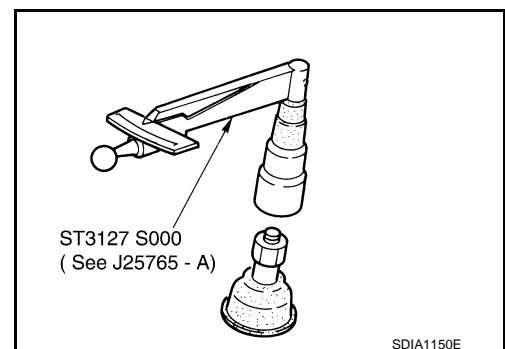

Axial End Play Inspection

- Move tip of ball stud in axial direction to check for looseness.

Axial end play : 0 mm (0 in)

- If it is outside the specified range, replace transverse link assembly.

TRANSVERSE LINK

[AWD]

< SERVICE INFORMATION >

INSTALLATION

- Installation is the reverse order of removal. For tightening torque, refer to [FSU-24. "Component"](#).
- Perform final tightening of bolts and nuts at the front suspension member installation position and the shock absorber lower side (rubber bushing) under unladen conditions with tires on level ground. Check wheel alignment. Refer to [FSU-22. "Wheel Alignment Inspection"](#).
- Adjust neutral position of steering angle sensor after checking wheel alignment. Refer to [BRC-8. "Adjustment of Steering Angle Sensor Neutral Position"](#).

A
B
C
D
E
F
G
H
I
J
K
L
M
N
O
P

FSU

UPPER LINK

Removal and Installation

INFOID:000000005347672

REMOVAL

1. Remove tires from vehicle with a power tool.
2. Remove shock absorber. Refer to [FSU-27](#).
3. Remove mounting nut and bolt with a power tool, and then remove upper link from steering knuckle.
4. Remove mounting nuts and bolts, and then remove upper link and stopper rubber from vehicle.

INSPECTION AFTER REMOVAL

Visual Inspection

Check the following:

- Upper link and bushing for deformation, cracks or damage. Replace it if a malfunction is detected.
- Ball joint boot for cracks or other damage, and also for grease leakage. Replace it if a malfunction is detected.

Ball Joint Inspection

Manually move ball stud to confirm it moves smoothly with no binding.

Swing Torque Inspection

NOTE:

Before measurement, move ball stud at least ten times by hand to check for smooth movement.

- Hook a spring balance at cutout on ball stud. Confirm spring balance measurement value is within specifications when ball stud begins moving.

Swing torque**: 0 - 2.0 N·m (0 - 0.2 kg·m, 0 - 17 in·lb)****Spring balance measurement****: 0 - 61.5 N (0 - 6.2 kg, 0 - 13.6 lb)**

- If it is outside the specified range, replace upper link assembly.

Axial End Play Inspection

- Move tip of ball stud in axial direction to check for looseness.

Axial end play : 0 mm (0 in)

- If it is outside the specified range, replace upper link assembly.

INSTALLATION

- Installation is the reverse order of removal. For tightening torque, refer to [FSU-24, "Component"](#).
- Perform final tightening of bolts and nuts at the vehicle installation position (rubber bushing) under unladen conditions with tires on level ground. Check wheel alignment. Refer to [FSU-22, "Wheel Alignment Inspection"](#).
- Adjust neutral position of steering angle sensor after checking wheel alignment. Refer to [BRC-8, "Adjustment of Steering Angle Sensor Neutral Position"](#).

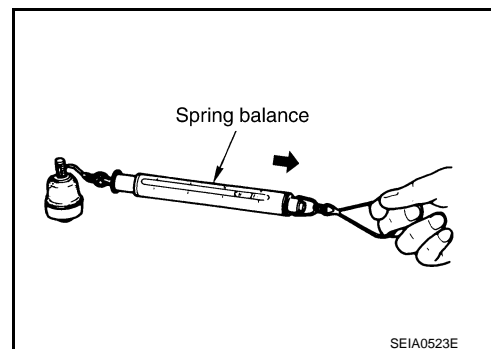

STABILIZER BAR

< SERVICE INFORMATION >

[AWD]

STABILIZER BAR

Removal and Installation

INFOID:000000005347673

REMOVAL

1. Remove tires from vehicle with a power tool.
2. Remove undercover with a power tool.
3. Remove the mounting nut on the lower side of stabilizer connecting rod with a power tool, and then remove stabilizer connecting rod from stabilizer bar.
4. If necessary remove the mounting nut on the upper side of stabilizer connecting rod with a power tool, and then remove stabilizer connecting rod from transverse link.
5. Remove the mounting nuts of stabilizer clamp, and then remove stabilizer clamp and stabilizer bushing.
6. Remove stabilizer bar from vehicle.

INSPECTION AFTER REMOVAL

Check stabilizer bar, stabilizer connecting rod, stabilizer bushing, and stabilizer clamp for deformation, cracks or damage. Replace it if a malfunction is detected.

INSTALLATION

Installation is the reverse order of removal. For tightening torque, refer to [FSU-24, "Component"](#).

A
B
C
D
E
F
G
H
I
J
K
L
M
N
O
P

FSU

SERVICE DATA AND SPECIFICATIONS (SDS)

< SERVICE INFORMATION >

[AWD]

SERVICE DATA AND SPECIFICATIONS (SDS)

Wheel Alignment (Unladen*)

INFOID:000000005347674

Item		Standard	
Tire		245/45 R18	
Camber Degree minute (Decimal degree)	Minimum	-1° 00' (-1.00°)	
	Nominal	-0° 15' (-0.25°)	
	Maximum	0° 30' (-0.50°)	
	Left and right difference	33' (0.55°) or less	
Caster Degree minute (Decimal degree)	Minimum	3° 05' (3.09°)	
	Nominal	3° 50' (3.83°)	
	Maximum	4° 35' (4.58°)	
	Left and right difference	39' (0.65°) or less	
Kingpin inclination Degree minute (Decimal degree)	Minimum	6° 30' (6.50°)	
	Nominal	7° 15' (7.25°)	
	Maximum	8° 00' (8.00°)	
Total toe-in	Distance	Minimum	0 mm (0 in)
		Nominal	In 1 mm (0.04 in)
		Maximum	In 2 mm (0.08 in)
	Angle (left wheel or right wheel) Degree minute (Decimal degree)	Minimum	0' (0°)
		Nominal	In 3' (0.05°)
		Maximum	In 6' (0.10°)

*: Fuel, engine coolant and lubricant are full. Spare tire, jack, hand tools and mats are in designated positions.

Ball Joint

INFOID:000000005347675

Item		Standard
Swing torque	Transverse link	0.5 – 3.6 N·m (0.06 – 0.36 kg-m, 5 – 31 in-lb)
	Upper link	0 – 2.0 N·m (0 – 0.2 kg-m, 0 – 17 in-lb)
Measurement on spring balance	Transverse link	7.8 – 56.3 N (0.8 – 5.7 kg, 1.8 – 12.5 lb)
	Upper link	0 – 61.5 N (0 – 6.2 kg, 0 – 13.6 lb)
Rotating torque	Transverse link	0.5 – 3.9 N·m (0.06 – 0.39 kg-m, 5 – 34 in-lb)
Axial end play		0 mm (0 in)

Wheelarch Height (Unladen*)

INFOID:000000005347676

U.S.A. model

Item	Standard
Tire size	245/45R18
Front (Hf)	731 mm (28.78 in)

SERVICE DATA AND SPECIFICATIONS (SDS)

< SERVICE INFORMATION >

[AWD]

Item	Standard
Tire size	245/45R18
Rear (Hr)	725 mm (28.54 in)

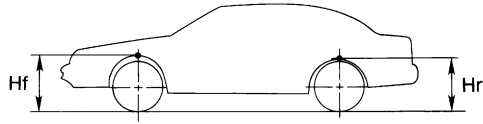

SFA818A

FSU

Canada model

Item	Standard
Tire size	245/45R18
Front (Hf)	732 mm (28.82 in)
Rear (Hr)	726 mm (28.58 in)

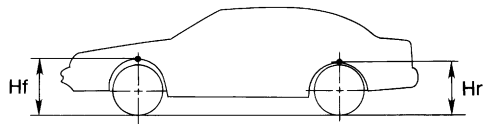

SFA818A